

Top View

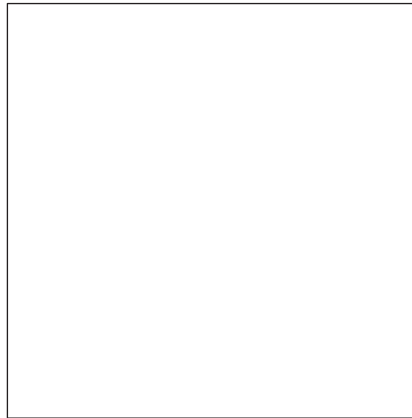

Bottom View

Porcelain Panel

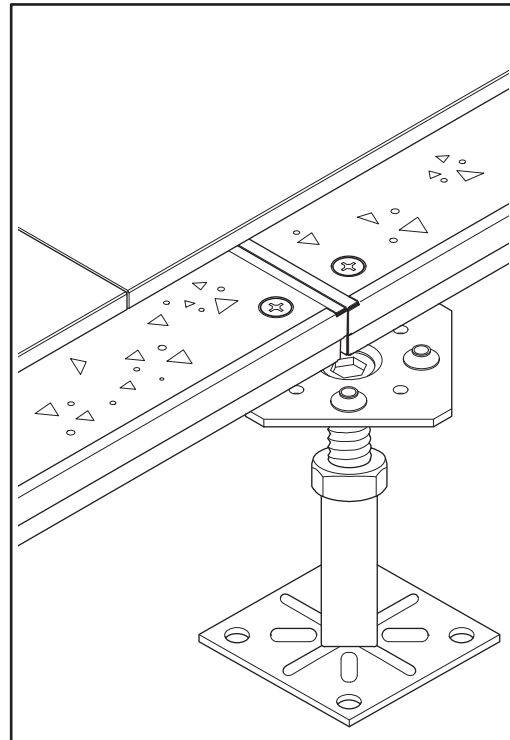
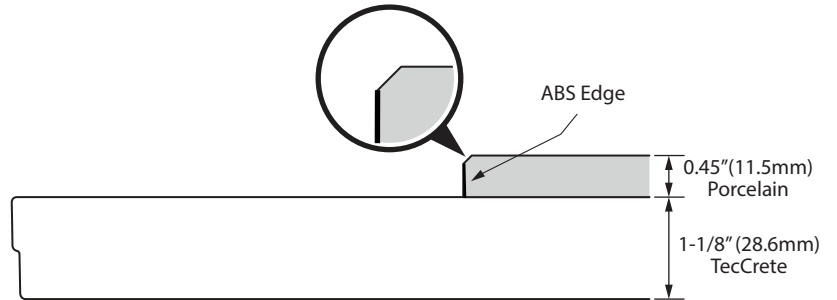

Elevate Porcelain Dry Lay  
Tile on top of TecCrete

### Specification

- 0.35" (9mm) Solid Porcelain Tile Surface
- 0.10" (2.5mm) Backer is a patented specific rubber material
- Edges of the panel are covered with 0.024" (0.6mm) self extinguishing sound minimizing ABS material
- Tile Size varies by series
  - 11.73" x 23.54" (298mm x 598mm)
  - 23.54" x 23.54" (598 x 598mm)
  - 23.43" x 23.43" (595mm x 595mm)
  - 23.43" x 46.93" (595mm x 1192mm)
  - 23.54" x 47.17" (598mm x 1198mm)
  - 11.73" x 47.17" (298mm x 1198mm)
- Tile Weight = 5.4 psf. Total Tile Weight = 20.58 lbs.

### System Loading

Product	Panel Thickness	Concentrated Edge Load	Deflection	Uniform Load	10-Pass	10-K Pass	Ultimate Load
Elevate Dry Lay	Elevate Dry Lay	700 psi	<.10"	600 psf	400	300	1350 psf